



The Mathematics Department

10

Powers

and Roots

Higher Tier

Version
3.0
08/2025

Name:

Contents

Chapter	Mathematics	Page Number
Rules of Indices	The index form. Evaluating the index form. The multiplication rule. The division rule. The zeroth index rule. Raising a power to another index. The negative index rule. The reciprocal as a negative index. Unitary fraction index rule. Algebra and rules of indices. The general fraction index rule.	3
Surds	Rational and irrational numbers. Surds. Simplifying surds. Expanding with surds.	12
Standard Form	Writing numbers $x \geq 1$ in standard form. Writing numbers $0 < x < 1$ in standard form. Changing from standard form to an ordinary number. Adding and subtracting in standard form. Almost in standard form. Multiplying and dividing in standard form.	16
Graph Plotting	Quadratic graphs. Recognising and sketching graphs of the form $y = ax^2 + b$. Graphical method of solving equations of the form $x^2 + ax + b = 0$. Other graphs.	22

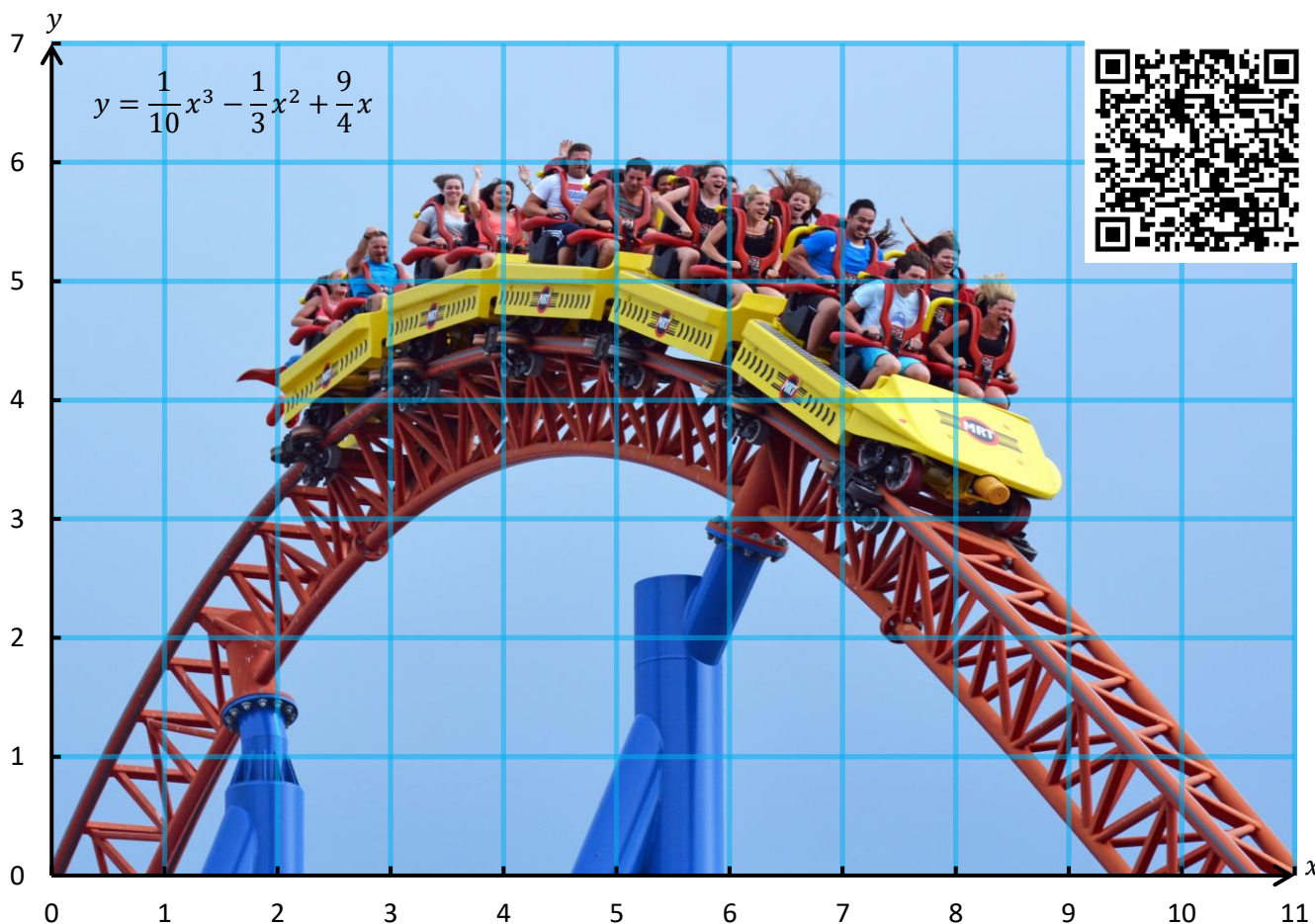

Rules of Indices

The Index Form

In year 8, we considered how to write a number as a product of its prime factors, in **index form**. For example, we can write 72 as a product of its prime factors, in index form, like this.

$$72 = 2^3 \times 3^2.$$

The index form is a product of terms of the form n^a . Each of these terms include a **base** and an **index**.

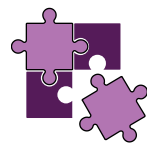

The base. This shows which number is getting multiplied in the term.

n^a

The index. This shows how many times the number n appears in the multiplication sum.

For example, we can write $7 \times 7 \times 7 \times 7 \times 7 \times 7 \times 7 \times 7 \times 7 \times 7$ as 7^{10} .

The **base** is 7, since 7 is the number which is being multiplied. The **index** is 10, since 7 appears 10 times.

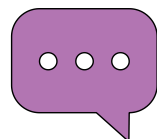

Other examples

$$5 \times 5 \times 5 \times 5 \times 5 \times 5 \times 5 = 5^7$$

The number **5** is being multiplied. It appears **7** times.

$$4 \times 4 \times 4 \times 4 \times 4 \times 4 = 4^6$$

The number **4** is being multiplied. It appears **6** times.

$$2 \times 2 \times 2 \times 3 \times 3 = 2^3 \times 3^2$$

The numbers **2** and **3** are being multiplied. **2** appears **3** times, and **3** appears **2** times.

Exercise 1

Write the following in index form.

(a) $3 \times 3 \times 3 \times 3 \times 3$

(b) $3 \times 3 \times 3 \times 3 \times 3 \times 3 \times 3 \times 3 \times 3 \times 3$

(c) $3 \times 3 \times 3 \times 3 \times 3 \times 3 \times 3 \times 3 \times 3$

(d) $3 \times 3 \times 3 \times 5 \times 5 \times 5 \times 5 \times 5$

(e) $3 \times 3 \times 3 \times 3 \times 3 \times 5 \times 5 \times 5$

(f) $3 \times 3 \times 3 \times 3 \times 3 \times 5$

(g) $2 \times 2 \times 7 \times 7 \times 7 \times 7 \times 9 \times 9 \times 9$

(h) $8 \times 8 \times 8 \times 33 \times 33 \times 33 \times 33$

(i) $3 \times 8 \times 8 \times 3 \times 8 \times 3 \times 3 \times 8$

(j) $3 \times 5 \times 5 \times 5 \times 3 \times 3 \times 7 \times 7$

(k) $2 \times 5 \times 7 \times 7 \times 2 \times 2 \times 2 \times 5$

(l) $13 \times 11 \times 7 \times 7 \times 11 \times 7$

Skill

A

Exercise 2

Write the following as multiplication sums without indices.

(a) 2^5

(b) 2^3

(c) 2^1

(d) 4^6

(e) 17^8

(f) 256^5

(g) $\left(\frac{1}{3}\right)^4$

(h) $2^4 \times 5^3$

(i) $4^4 \times 5^5$

(j) $24^3 \times 45^4$

(k) $\left(\frac{1}{5}\right)^3 \times \left(\frac{3}{4}\right)^3$

(l) $5^3 \times 13^2 \times 27^4$

(m) $3^2 \times 5^4 \times 10^2 \times 14^3$

(n) $2^3 \times \left(\frac{1}{2}\right)^3 \times 4^3$

(o) $\left(\frac{3}{7}\right)^2 \times \left(\frac{3}{4}\right)^4 \times \left(\frac{7}{9}\right)^3$



Investigation

Who was **Pierre de Fermat**? What was his contribution to mathematics? What was his last theorem? When was this theorem proved? Are there other theorems connected to index form?



Evaluating the Index Form

Evaluating index form is the process of writing a number written in index form as an ordinary number. For example, we can write 3^4 as $3 \times 3 \times 3 \times 3$, which is equal to 81.



Other examples

$$4^3 = 4 \times 4 \times 4 = 64$$

$$5^4 = 5 \times 5 \times 5 \times 5 = 625$$

$$2^4 + 7^3 = (2 \times 2 \times 2 \times 2) + (7 \times 7 \times 7) = 16 + 343 = 359$$

Exercise 3

Evaluate the following, without using a calculator.



- (a) 3^4
- (b) 6^3
- (c) 10^5
- (d) 2^9
- (e) 20^4
- (f) $3^2 + 2^5$
- (g) $6^3 - 3^4$
- (h) $6^3 \times 2^2$
- (i) $10^4 \div 2^2$
- (j) $5^4 + 4^4$

Exercise 4

Use your calculator to evaluate the following. If appropriate, write your answer correct to 2 decimal places.

- (a) 125^2
- (b) 17^4
- (c) $29^3 + 5$
- (d) $9^3 + 5$
- (e) $12^4 - 5^6$
- (f) $12^3 + 3^7$
- (g) $3^4 \times 4^5$
- (h) $2^3 \times 4^2 + 3^2$
- (i) $(4^3)^4$
- (j) $4^6 \div 2^6 + 10^3$
- (k) $11^3 - 4^4$
- (l) $4^5 - 5^6$
- (m) $3^8 + 4^{10} - 5^6$
- (n) $4^6 - 3^2 \times 8^3$
- (o) $3^4 + 8^8 \div 4^{10}$
- (p) $\frac{5^6}{3^7}$
- (q) $\frac{4^4 + 3^6}{2^4}$
- (r) $\frac{11^3}{2^5 \times 3^5}$
- (s) $\frac{4^3 + 6^4 \times 2^3}{10^3 - 5^3}$
- (t) $\left(\frac{4^3 + 6^4 \times 2^3}{10^3 - 5^3}\right)^3$

Exercise 5



(a) Without using a calculator, calculate the numbers which fill the following spaces.

- (i) $2^{12} = 4096$
- (ii) $4^6 = 4096$
- (iii) $3^{11} = 177147$
- (iv) $5^5 = 3125$
- (v) $8^3 = 512$
- (vi) $2^{11} = \underline{\hspace{2cm}}$
- (vii) $4^7 = \underline{\hspace{2cm}}$
- (viii) $3^{12} = \underline{\hspace{2cm}}$
- (ix) $5^4 = \underline{\hspace{2cm}}$
- (x) $8^4 = \underline{\hspace{2cm}}$
- (vi) $2^8 = 256$
- (vii) $6^4 = 1296$
- (viii) $3^7 = 2187$
- (ix) $5^9 = 1953125$
- (x) $7^4 = 2401$
- (vi) $2^{10} = \underline{\hspace{2cm}}$
- (vii) $6^6 = \underline{\hspace{2cm}}$
- (viii) $3^9 = \underline{\hspace{2cm}}$
- (ix) $5^7 = \underline{\hspace{2cm}}$
- (x) $7^6 = \underline{\hspace{2cm}}$

(b) Put the numbers 1 to 6 into the following boxes to make:

$$\square^{\square} + \square^{\square} + \square^{\square}$$

- (i) The largest possible number;
- (ii) The smallest possible number;
- (iii) A total of 147.



(c) Put the numbers 1 to 6 into the following boxes to make the calculation correct.

$$\square^{\square} + \square^{\square} = \square \square$$

(d) Write any whole numbers in the following boxes to make the calculation correct. How many possible solutions are there?

$$\square^{\square} = 64$$



Exercise 6

Write the digits 1 to 9 in the grid on the right so that each row (reading across) is a square number. You may use each digit once only.

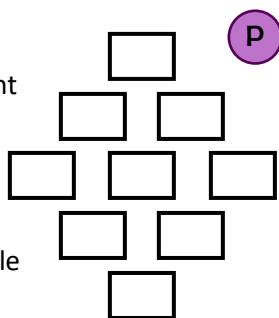

Can you prove that there is only one possible solution?

Rules of Indices

When performing calculations in index form, we notice several different patterns. The **rules of indices** write these patterns in a convenient way.

The Multiplication Rule

$$n^a \times n^b = n^{a+b}$$

When multiplying one number or variable to an index, by the **same** number or variable to another index, we must **add** the indices. We can see below why this is true.

$$8^4 \times 8^3 = 8 \times 8 \times 8 \times 8 \times 8 \times 8 \times 8 \\ = 8^7.$$

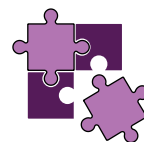

Other examples

$$4^3 \times 4^6 = 4^{3+6} \\ = 4^9$$

$$8^2 \times 8^9 = 8^{2+9} \\ = 8^{11}$$

$$a^5 \times a^6 \times a^4 = a^{5+6+4} \\ = a^{15}$$

$$7^9 \times 7^{-3} = 7^{9+(-3)} \\ = 7^6$$

Exercise 8

Simplify each of the following expressions.

(a) $7^5 \times 7^3$

(b) $7^3 \times 7^5$

(c) $8^5 \times 8$

(d) $x^5 \times x^3$

(e) $7^4 \times 7^8$

(f) $a^5 \times a^3$

(g) $a^5 \times a^7 \times a^{10}$

(h) $3^2 \times 3^9 \times 3^4$

(i) $5^5 \times 5^2 \times 5^{12}$

(j) $y^3 \times y^{13} \times y^{16}$

(k) $7^{15} \times 7^{-4}$

(l) $14^9 \times 14^{-6}$

(m) $8^{-10} \times 8^3$

(n) $d^5 \times d^{-8}$

(o) $f^{-4} \times f^{-3}$

(p) $i^{-5} \times i^{11} \times i^{-3}$

(q) $p^{-9} \times p^{-2} \times p^5$

(r) $4^{-17} \times 4^{-7} \times 4^{31}$

(s) $(-5)^5 \times (-5)^3$

(t) $(-5)^5 \times (-5)^{-3}$

(u) $(-5)^{-5} \times (-5)^{-3}$

(v) $a^3 \times a^{\frac{1}{2}}$

(w) $a^{\frac{3}{5}} \times a^{\frac{1}{5}}$

(x) $a^{\frac{2}{3}} \times a^{\frac{4}{7}}$

(y) $a^{\frac{8}{3}} \times a^{\frac{5}{4}}$

Exercise 9

Find the missing numbers that go into the boxes in all of the following questions.

(a) $7^5 \times 7^{\square} = 7^8$

(b) $7^{\square} \times 7^4 = 7^6$

(c) $7^{13} \times 7^{\square} = 7^{11}$

(d) $7^8 \times 7^4 = 7^{\square}$

(f) $5^5 \times 5^{\square} = 5^6$

(g) $4^9 \times 4^{\square} = 4^8$

(h) $11^{\square} \times 11^{10} = 11^7$

(i) $2^{\square} \times 2^{-5} = 2^9$

(e) $x^2 \times x^{\square} = x^{14}$

(j) $8^{-2} \times 8^{\square} = 8^{-9}$

Challenge!

An **Armstrong Number** is a whole number where the sum of the digits, each raised to the number of digits, is equal to the original number.

For example, the number 371 is an Armstrong number since $3^3 + 7^3 + 1^3 = 371$.

1,634 is also an Armstrong number since $1^4 + 6^4 + 3^4 + 4^4 = 1,634$.

How many Armstrong numbers are there between 1 and 10,000?

Exercise 7

Complete the following crossnumber.

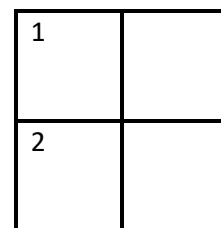

Clues:

Across

- Cube number
- Cube number

Down

- One less than a cube number



2



The Division Rule



$$n^a \div n^b = n^{a-b} \text{ or } \frac{n^a}{n^b} = n^{a-b}$$

When dividing one number or variable to an index, by the **same** number or variable to another index, we must **subtract** the indices. We can see below why this is true.

$$\begin{aligned} \frac{7^8}{7^5} &= \frac{7 \times 7 \times 7 \times 7 \times 7 \times 7 \times 7 \times 7}{7 \times 7 \times 7 \times 7 \times 7} \\ &= \frac{7 \times 7 \times 7 \times 7 \times 7 \times 7 \times 7 \times 7}{7 \times 7 \times 7 \times 7 \times 7} \\ &= 7 \times 7 \times 7 \\ &= 7^3. \end{aligned}$$



Other Examples

$$\begin{aligned} 4^6 \div 4^3 &= 4^{6-3} \\ &= 4^3 \end{aligned}$$

$$\begin{aligned} 8^9 \div 8^2 &= 8^{9-2} \\ &= 8^7 \end{aligned}$$

$$\begin{aligned} \frac{a^7}{a^4} &= a^{7-4} \\ &= a^3 \end{aligned}$$

$$\begin{aligned} 6^5 \div 6^{-2} &= 6^{5-(-2)} \\ &= 6^7 \end{aligned}$$

Exercise 10

Simplify each of the following expressions.

(a) $7^5 \div 7^3$

(b) $7^3 \div 7^5$

(c) $7^{11} \div 7$

(d) $7^8 \div 7^4$

(e) $x^5 \div x^3$

(f) $a^5 \div a^3$

(g) $a^5 \div a^7$

(h) $\frac{3^9}{3^2}$

(i) $\frac{5^{15}}{5^{12}}$

(j) $\frac{y^3}{y^{16}}$

(k) $7^{15} \div 7^{-4}$

(l) $14^9 \div 14^{-6}$

(m) $8^{-10} \div 8^3$

(n) $d \div d^{-8}$

(o) $f^{-4} \div f^{-3}$

(p) $i^{-5} \div i^{-3}$

(q) $p^{-9} \div p^{-2} \div p^5$

(r) $4^{-17} \div 4^{-7} \div 4^{31}$

(s) $(-5)^5 \div (-5)^3$

(t) $(-5)^5 \div (-5)^{-3}$

(u) $(-5)^{-5} \div (-5)^{-3}$

(v) $a^3 \div a^{\frac{1}{2}}$

(w) $a^{\frac{3}{5}} \div a^{\frac{1}{5}}$

(x) $a^{\frac{2}{3}} \div a^{\frac{4}{7}}$

(y) $a^{\frac{8}{3}} \div a^{\frac{5}{4}}$

Exercise 11

Find the missing numbers that go into the boxes in all of the following questions.

(a) $7^5 \div 7^{\square} = 7^2$

(b) $7^{\square} \div 7^4 = 7^6$

(c) $7^{13} \div 7^{\square} = 7^{11}$

(d) $7^6 \div 7^4 = 7^{\square}$

(e) $x^{15} \div x^{\square} = x^7$

(f) $5^5 \div 5^{\square} = 5^7$

(g) $\frac{4^9}{4^{\square}} = 4^5$

(h) $\frac{11^{30}}{11^{\square}} = 11^{14}$

(i) $2^{\square} \div 2^{-5} = 2^{-2}$

(j) $8^{-2} \div 8^{\square} = 8^{-9}$

Example

$$\begin{aligned} 3^7 \times 3^5 \div 3^2 &= 3^{7+5} \div 3^2 \\ &= 3^{12} \div 3^2 \\ &= 3^{12-2} \\ &= 3^{10} \end{aligned}$$

$$\begin{aligned} 3^9 \div 3^2 \times 3^5 &= 3^{9-2} \times 3^5 \\ &= 3^7 \times 3^5 \\ &= 3^{7+5} \\ &= 3^{12} \end{aligned}$$

$$\begin{aligned} \frac{y^7}{y^4} \times y^{10} &= y^{7-4} \times y^{10} \\ &= y^3 \times y^{10} \\ &= y^{3+10} \\ &= y^{13} \end{aligned}$$

Exercise 12

Simplify each of the following expressions.

(a) $3^5 \times 3^6 \div 3^2$

(b) $6^8 \times 6^6 \div 6^7$

(c) $7^{11} \times 7^5 \div 7^8$

(d) $5^8 \times 5^3 \div 5^4$

(e) $x^9 \times x^3 \div x^4$

(f) $a^5 \times a^4 \div a^8$

(g) $a^{10} \times a^{-5} \div a^7$

(h) $2^{13} \div 2^3 \times 2^4$

(i) $5^7 \div 5^2 \times 5^4$

(j) $8^9 \div 8 \times 8^3$

(k) $5^8 \times 5^3 \times 5^7 \div 5^4$

(l) $4^9 \div 4^2 \times 4^3 \div 4^5$

(m) $8^{-4} \times 8^3 \times 8^6$

(n) $d^5 \div d^{-8} \times d^4$

(o) $u^{-3} \div u^{-3} \times u^{-3}$

(p) $\frac{10^6}{10^2} \times 10^8$

(q) $\frac{7^9}{7^3} \times 7^2$

(r) $19^4 \times \frac{19^{12}}{19^3}$

(s) $4^9 \div \frac{4^6}{4^2}$

(t) $e^8 \times \frac{e^6}{e^3}$

(u) $\frac{4^5 \times 4^7}{4^3}$

(v) $\frac{15^7 \times 15}{15^2}$

(w) $\frac{6^{10}}{6^2 \times 6^5}$

(x) $\frac{r^6 \times r^{-1}}{r^{-2}}$

(y) $\frac{q^{-3}}{q^4 \times q^{-8}} \times q^3$

The Zeroth Index Rule



$$n^0 = 1$$

Any number or variable raised to a zero index gives the answer **1**. Why? Let us consider the following calculations.

$$\frac{3^2}{3^2} = \frac{9}{9} = 1$$

$$\frac{7^2}{7^2} = \frac{49}{49} = 1$$

$$\frac{12^2}{12^2} = \frac{144}{144} = 1$$

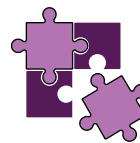

But the division rule states that

$$\frac{3^2}{3^2} = 3^{2-2} = 3^0$$

$$\frac{7^2}{7^2} = 7^{2-2} = 7^0$$

$$\frac{12^2}{12^2} = 12^{2-2} = 12^0$$



So, we must have

$$3^0 = 1$$

$$7^0 = 1$$

$$12^0 = 1$$

This would work for any number or variable, not just 3 or 7 or 12.

Exercise 13

Evaluate the following.

- (a) 3^0
- (b) 28^0
- (c) 37648^0
- (d) $19^0 \times 27^0$
- (e) $19^0 + 27^0$
- (f) x^0
- (g) π^0
- (h) $2^3 \times 2^0$
- (i) $3^4 \div 3^0$
- (j) $\frac{7^5}{7^5}$

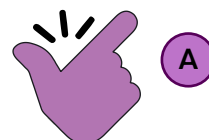

Raising a Power to Another Index

$$(n^a)^b = n^{a \times b}$$



If a power of the form n^a is raised to another index, then we need to **multiply** the indices. We can see below why this is true.

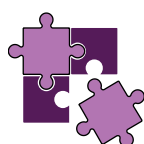

$$\begin{aligned} (5^3)^4 &= \overbrace{5^3 \times 5^3 \times 5^3 \times 5^3}^{4 \text{ times}} \\ &= 5^{3+3+3+3} \\ &= 5^{12} \\ &= 5^{3 \times 4} \end{aligned}$$

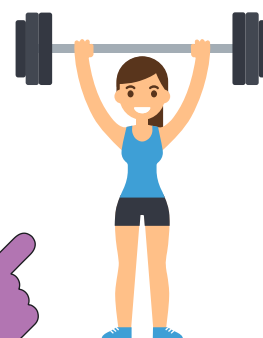

Exercise 14

2

Simplify the following, giving your answers in index form.

- (a) $(5^2)^4$
- (b) $(5^4)^2$
- (c) $(7^2)^4$
- (d) $(x^2)^4$
- (e) $((-5)^2)^4$
- (f) $(5^{-2})^4$
- (g) $(5^2)^{-4}$
- (h) $(5^{-2})^{-4}$
- (i) $\left(\left(\frac{1}{5}\right)^2\right)^4$
- (j) $(5^2)^0$
- (k) $(6^3)^6$
- (l) $(11^{25})^3$
- (m) $(2^7)^8$
- (n) $(43^5)^{-7}$
- (o) $(10^{-3})^{-9}$
- (p) $(9^0)^6$
- (q) $(0.3^6)^9$
- (r) $(11^{-9})^7$
- (s) $((-3)^{-4})^{-3}$
- (t) $(y^{14})^3$
- (u) $(5^2)^4 \times 5^6$
- (v) $(3^6)^2 \div 3^4$
- (w) $(8^5)^2 \div 8^{10}$
- (x) $6 \times (6^5)^3$
- (y) $(4^{12})^5 \times 4^0$



The Negative Index Rule



$$n^{-a} = \frac{1}{n^a}$$

Any number or variable raised to a **negative** index can be written as a fraction whose numerator is 1. Why? Let us consider the following sequences.

$$\begin{aligned} 7^3 &= 7 \times 7 \times 7 \\ 7^2 &= 7 \times 7 \quad \div 7 \\ 7^1 &= 7 \quad \div 7 \\ 7^0 &= 1 \quad \div 7 \end{aligned}$$

$$\begin{aligned} 15^3 &= 15 \times 15 \times 15 \\ 15^2 &= 15 \times 15 \quad \div 15 \\ 15^1 &= 15 \quad \div 15 \\ 15^0 &= 1 \quad \div 15 \end{aligned}$$

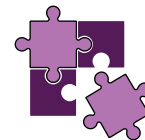

What will appear next in these sequences?

$$\begin{aligned} 7^0 &= 1 \\ 7^{-1} &= \frac{1}{7} \quad \div 7 \\ 7^{-2} &= \frac{1}{7 \times 7} \quad \div 7 \end{aligned}$$

$$\begin{aligned} 15^0 &= 1 \\ 15^{-1} &= \frac{1}{15} \quad \div 15 \\ 15^{-2} &= \frac{1}{15 \times 15} \quad \div 15 \end{aligned}$$

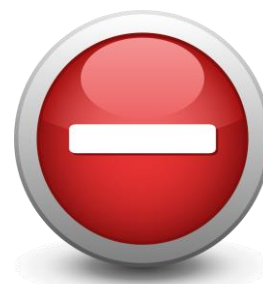

Exercise 15

A

Complete the following table.

n	5	4	3	2	1	0	-1	-2	-3	-4	-5
2^n	32										

Exercise 16

Write the following as ordinary fractions, without using indices.

- (a) 3^{-2}
- (b) 4^{-2}
- (c) 5^{-2}
- (d) 3^{-3}
- (e) 4^{-3}
- (f) 3^{-4}
- (g) 8^{-2}
- (h) 7^{-1}
- (i) 10^{-4}
- (j) 11^{-2}
- (k) $2^{-2} \times 3$
- (l) $6^{-2} \div 2$
- (m) $8^{-1} \times 4$
- (n) $9^{-2} \times 2^{-1}$
- (o) $2^{-1} + 2^{-3}$



The Reciprocal as a Negative Index

In year 9, we defined the **reciprocal** of a number as follows:

$$\text{The reciprocal of a number is } \frac{1}{\text{the number}}$$

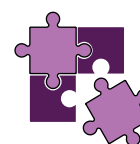

For example, the reciprocal of 4 is $\frac{1}{4}$ and the reciprocal of 15 is $\frac{1}{15}$. Because $n^{-1} = \frac{1}{n^1} = \frac{1}{n}$, we can now define the reciprocal of a number in an alternative way:

$$\text{The reciprocal of a number } n \text{ is } n^{-1}.$$

Exercise 17

Prove that multiplying a number n by its reciprocal n^{-1} always gives an answer of 1. (Clue: You will need to use the multiplication rule from page 5.)

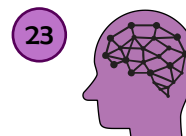

Unitary Fraction Index Rule



$$\frac{1}{n^a} = \sqrt[a]{n}$$

Any number or variable raised to an index that is a **unitary fraction** of the form $\frac{1}{a}$ can be written as the **a-th root** of n . For example, if $a = 4$ then n raised to a quarter ($n^{\frac{1}{4}}$) can be written as the fourth root of n ($\sqrt[4]{n}$).

Why is this true? Consider the following application of the rule $(n^a)^b = n^{a \times b}$ from page 7.

$$\left(n^{\frac{1}{2}}\right)^2 = n^{\frac{1}{2} \times 2}$$

$$\left(n^{\frac{1}{3}}\right)^3 = n^{\frac{1}{3} \times 3}$$

$$\left(n^{\frac{1}{2}}\right)^2 = n^1$$

$$\left(n^{\frac{1}{3}}\right)^3 = n^1$$

$$\left(n^{\frac{1}{2}}\right)^2 = n$$

$$\left(n^{\frac{1}{3}}\right)^3 = n$$



Because the square root of a number is a number that squares to give the original number, we have $n^{\frac{1}{2}} = \sqrt{n}$.

Because the cube root of a number is a number that cubes to give the original number, we have $n^{\frac{1}{3}} = \sqrt[3]{n}$.

Example

$$\frac{1}{9^2} = \sqrt{9} = 3$$

$$216^{\frac{1}{3}} = \sqrt[3]{216} = 6$$

$$625^{\frac{1}{4}} = \sqrt[4]{625} = 5$$

$5^4 = 5 \times 5 \times 5 \times 5 = 625$ therefore $\sqrt[4]{625} = 5$.

Exercise 18

Evaluate the following.



P

(a) $16^{\frac{1}{2}}$

(b) $25^{\frac{1}{2}}$

(c) $49^{\frac{1}{2}}$

(d) $8^{\frac{1}{3}}$

(e) $27^{\frac{1}{3}}$

(f) $16^{\frac{1}{4}}$

(g) $81^{\frac{1}{4}}$

(h) $64^{\frac{1}{2}}$

(i) $64^{\frac{1}{3}}$

(j) $64^{\frac{1}{6}}$

(k) $36^{\frac{1}{2}} \times 9^{\frac{1}{2}}$

(l) $125^{\frac{1}{3}} + 81^{\frac{1}{2}}$

(m) $100^{\frac{1}{2}} \div 4^{\frac{1}{2}}$

(n) $32^{\frac{1}{5}} - 1^{\frac{1}{3}}$

(o) $121^{\frac{1}{2}} \times 0^{\frac{1}{10}}$

Exercise 19 (Revision)

Simplify each of the following expressions.

(a) $2^{10} \times 2^5$

(b) $3^5 \times 3$

(c) $15^6 \times 15^{-2}$

(d) $x^{-4} \times x^9$

(e) $4^{-3} \times 4^{-2}$

(f) $2^{10} \div 2^5$

(g) $3^5 \div 3$

(h) $15^6 \div 15^{-2}$

(i) $x^{-4} \div x^9$

(j) $4^{-3} \div 4^{-2}$

(k) 2^0

(l) 45^0

(m) $(2^{10})^5$

(n) $(15^6)^{-2}$

(o) $(4^{-3})^{-2}$

(p) 7^{-2}

(q) 5^{-3}

(r) $81^{\frac{1}{2}}$

(s) $343^{\frac{1}{3}}$

(t) $\frac{16^{\frac{1}{2}}}{2^{-2}}$

Exercise 20

Complete the following pyramids, where each number is the product of the two numbers in the boxes underneath.

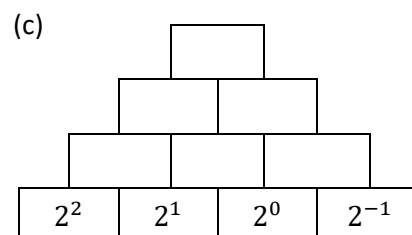
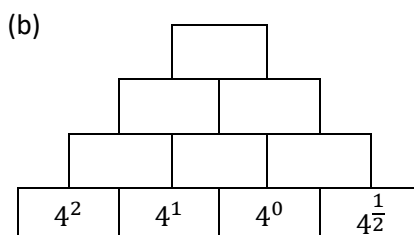
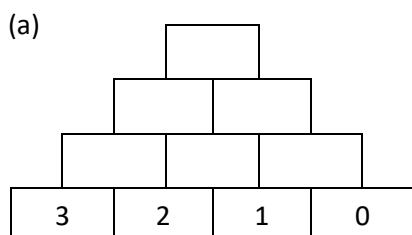

Algebra and Rules of Indices

Multiply the numbers, add the indices.

Divide the numbers, subtract the indices.

Example

$$4x^2y^3 \times 3x^4y^5 = 12x^6y^8$$

$$20a^8b^6 \div 4a^2b^3 = 5a^6b^3$$

$$\frac{42p^{12}q^{15}}{6p^3q^5} = 7p^9q^{10}$$



Exercise 21

Simplify the following algebraic expressions.

Skill
23

(a) $2x^3y^4 \times 3x^4y^2$

(b) $8a^5b^3 \times 4a^3b^6$

(c) $9p^5q^3 \times 3p^4q$

(d) $16x^{10}y^{12} \div 2x^2y^4$

(e) $24a^6b^{15} \div 4a^2b^3$

(f) $80p^{32}q^{20} \div 10p^4q^{10}$

(g) $\frac{8x^{14}y^{10}}{2x^2y^2}$

(h) $\frac{28a^{16}b^4}{7a^4b}$

(i) $\frac{100p^4q^8}{25p^2q^4}$

(j) $4g^5h^3 \times -2g^5h^3$

(k) $6s^4t^6 \times 5s^{-2}t^3$

(l) $-3u^{-5}v^7 \times -9u^3v^{-2}$

(m) $25c^8d^{-12} \div 5c^2d^3$

(n) $\frac{-32e^{-4}f^{10}}{2ef^2}$

(o) $\frac{84x^5y^{-14}z}{2x^{-2}y^2z^{-2}}$

The General Fraction Index Rule

$$\left(\sqrt[b]{n}\right)^a = n^{\frac{a}{b}} = \sqrt[b]{n^a}$$

There are two ways of writing any number or variable raised to a **general fraction** of the form $\frac{a}{b}$.



- (1) Take the b -th root of n to begin with, and then raise everything to the index a .
- (2) Raise n to the index a to begin with, and then take the b -th root of everything.

$$\left(\sqrt[b]{n}\right)^a = \sqrt[b]{n^a}$$

Example

Evaluate $27^{\frac{2}{3}}$.

Evaluate $32^{\frac{3}{5}}$.

Method (1) $\sqrt[3]{27} = 3$
Method (2) $27^2 = 729$
 $3^2 = 9$ $\sqrt[3]{729} = 9$

Method (1) $\sqrt[5]{32} = 2$
Method (2) $32^3 = 32,768$
 $2^3 = 8$ $\sqrt[5]{32,768} = 8$

Usually, method (1) is easier to calculate without a calculator.

Exercise 22

Evaluate the following.

(a) $8^{\frac{2}{3}}$

(b) $8^{\frac{4}{3}}$

(c) $125^{\frac{2}{3}}$

(d) $125^{\frac{4}{3}}$

(e) $81^{\frac{3}{4}}$

(f) $16^{\frac{3}{2}}$

(g) $32^{\frac{2}{5}}$

(h) $32^{\frac{4}{5}}$

(i) $49^{\frac{3}{2}}$

(j) $64^{\frac{2}{3}}$

(k) $16^{\frac{3}{4}}$

(l) $1024^{\frac{2}{5}}$

(m) $144^{\frac{3}{2}}$

(n) $3125^{\frac{2}{5}}$

(o) $1296^{\frac{3}{4}}$

(p) $625^{\frac{3}{4}}$

(q) $243^{\frac{2}{5}}$

(r) $36^{\frac{3}{2}}$

(s) $4^{\frac{5}{2}}$

(t) $729^{\frac{2}{3}}$

Challenge!

- (a) Given that x is a number such that $x > 1$, put x, x^2, x^{-1} in ascending order.
- (b) Given that x is a number such that $0 < x < 1$, put x, x^2, x^{-1} in ascending order.
- (c) Given that x is a number such that $0 < x < 1$, put $x, x^0, x^{\frac{1}{2}}$ in ascending order.
- (d) Given that x is a number such that $-1 < x < 0$, put $x, x^2, x^0, x^{-1}, x^{-3}$ in ascending order.

Extension





Combining the Rules

Example

$$4^{-\frac{1}{2}} = \frac{1}{4^{\frac{1}{2}}}$$

$$= \frac{1}{\sqrt{4}}$$

$$= \frac{1}{2}$$

$$8^{-\frac{2}{3}} = \frac{1}{8^{\frac{2}{3}}}$$

$$= \frac{1}{(\sqrt[3]{8})^2}$$

$$= \frac{1}{2^2}$$

$$= \frac{1}{4}$$

The negative index gives a unitary fraction

The fractional index gives a root

Evaluate the answer



Exercise 23

Evaluate the following.

(a) $25^{-\frac{1}{2}}$

(b) $36^{-\frac{1}{2}}$

(c) $64^{-\frac{1}{2}}$

(d) $64^{-\frac{1}{3}}$

(e) $27^{-\frac{1}{3}}$

(f) $16^{-\frac{1}{4}}$

(g) $1024^{-\frac{1}{5}}$

(h) $144^{-\frac{1}{2}}$

(i) $125^{-\frac{1}{3}}$

(j) $81^{-\frac{1}{4}}$

(k) $27^{-\frac{2}{3}}$

(l) $4^{-\frac{3}{2}}$

(m) $216^{-\frac{2}{3}}$

(n) $81^{-\frac{3}{4}}$

(o) $32^{-\frac{3}{5}}$

(p) $16^{-\frac{3}{2}}$

(q) $256^{-\frac{3}{4}}$

(r) $25^{-\frac{3}{2}}$

(s) $243^{-\frac{3}{5}}$

(t) $8^{-\frac{4}{3}}$

Exercise 24

Evaluate the following.

(a) $\left(\frac{9}{16}\right)^{\frac{1}{2}}$

(b) $\left(\frac{27}{125}\right)^{\frac{1}{3}}$

(c) $\left(\frac{1}{36}\right)^{\frac{1}{2}}$

(d) $\left(\frac{1}{16}\right)^{\frac{1}{4}}$

(e) $\left(\frac{36}{49}\right)^{\frac{1}{2}}$

(f) $\left(\frac{1}{4}\right)^{-\frac{1}{2}}$

(g) $\left(\frac{36}{121}\right)^{-\frac{1}{2}}$

(h) $\left(\frac{8}{27}\right)^{-\frac{1}{3}}$

(i) $\left(\frac{125}{343}\right)^{-\frac{1}{3}}$

(j) $\left(\frac{1}{81}\right)^{-\frac{1}{4}}$

(k) $\left(3\frac{1}{16}\right)^{\frac{1}{2}}$

(l) $\left(3\frac{3}{8}\right)^{\frac{1}{3}}$

(m) $\left(2\frac{1}{4}\right)^{-\frac{1}{2}}$

(n) $\left(2\frac{10}{27}\right)^{-\frac{1}{3}}$

(o) $\left(37\frac{1}{27}\right)^{-\frac{1}{3}}$

Challenge!

What is the answer to $\sqrt{9}$? One answer is 3, as $3^2 = 9$. But -3 is also an answer, as $(-3)^2 = 9$. How many different answers do the following calculations have?

(a) $\sqrt{16}$

(b) $\sqrt[3]{27}$

(c) $\sqrt[4]{16}$

(d) $9^{\frac{1}{2}}$

(e) $3125^{\frac{1}{5}}$



Evaluation

Key words	Corrections	I am happy with...	I need to revise...

Surds



Rational and Irrational Numbers

A number is a **rational number** if it can be written in the form of a fraction $\frac{a}{b}$, where a and b are integers, and $b \neq 0$. For example, $\frac{4}{5}$, $6 = \frac{6}{1}$, $3\frac{1}{2} = \frac{7}{2}$ and $0.\dot{3} = \frac{1}{3}$ are rational numbers.

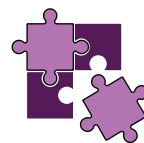

A number is an **irrational number** if it **cannot** be written in the form of a fraction $\frac{a}{b}$, where a and b are integers, and $b \neq 0$. For example, π , $\sqrt{2}$ and $0.202002000200002\dots$ are irrational numbers.

Exercise 25



Circle the rational numbers below.

- | | | | | | | |
|---------------|----------------|----------------|------------|----------------|---------------------|-------------------------|
| 8 | $\sqrt{3}$ | $\frac{5}{6}$ | $\sqrt{4}$ | π | $0.\dot{4}5\dot{2}$ | $0.45445444544445\dots$ |
| $\sqrt[3]{2}$ | $4\frac{2}{3}$ | $\sqrt[3]{27}$ | π^2 | $(\sqrt{2})^2$ | $\frac{2}{0}$ | 0.27277277727777 |

Surds

A **surd** is a number that contains a root that does not correspond to a rational number. Here are some examples.

- | | |
|----------------|--|
| $\sqrt{2}$ | Surd (it is not possible to write $\sqrt{2}$ as a fraction $\frac{a}{b}$). |
| $3\sqrt{2}$ | Surd (a multiple of the surd $\sqrt{2}$). |
| $\sqrt{9}$ | Not a surd (corresponds to 3). |
| $\sqrt[3]{4}$ | Surd (it is not possible to write $\sqrt[3]{4}$ as a fraction $\frac{a}{b}$). |
| $\sqrt[3]{64}$ | Not a surd (corresponds to 4). |

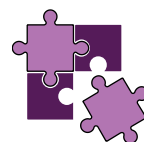

Exercise 26

Circle the surds below.

- | | | | | | | |
|---------------|----------------|-------------|-------------|---------------|----------------|-----------------|
| $\sqrt{5}$ | $\sqrt{16}$ | $\sqrt{49}$ | $\sqrt{32}$ | $\sqrt[3]{4}$ | $\sqrt[3]{1}$ | $\sqrt[3]{25}$ |
| $\sqrt[4]{2}$ | $\sqrt[4]{16}$ | $9\sqrt{2}$ | $2\sqrt{4}$ | $3\sqrt{10}$ | $6\sqrt[3]{8}$ | $4\sqrt[3]{36}$ |



Working with surds

It is possible to collect like surds together, exactly as we can collect like terms in algebra.

Example

$$2\sqrt{3} + 4\sqrt{3} = 6\sqrt{3}$$

$$7\sqrt{2} - \sqrt{2} = 6\sqrt{2}$$

$$4\sqrt[3]{5} + 2\sqrt[3]{5} + 6\sqrt[3]{5} + 7\sqrt[3]{5} = 10\sqrt[3]{5} + 9\sqrt[3]{5}$$

$$5\sqrt{6} + \sqrt{16} - 2\sqrt{6} - 1 = 3\sqrt{6} + 3$$

Exercise 27

Simplify the following.

(a) $5\sqrt{2} + 3\sqrt{2}$

(b) $7\sqrt{2} + \sqrt{2}$

(c) $6\sqrt{2} - 2\sqrt{2}$

(d) $8\sqrt[3]{7} + 2\sqrt[3]{7}$

(e) $10\sqrt[4]{2} - 3\sqrt[4]{2}$

(f) $\sqrt{3} + 2 + \sqrt{3} + 9$

(g) $5\sqrt{7} + 2\sqrt[3]{4} + 2\sqrt{7} + 6\sqrt[3]{4}$

(h) $7\sqrt[3]{5} + \sqrt{11} - 4\sqrt[3]{5} + 2\sqrt{11}$

(i) $3\sqrt[4]{4} + 2\sqrt{6} + 8$

(j) $\sqrt{10} + 3\sqrt[4]{3} - 3\sqrt{10} + \sqrt[4]{3}$

(k) $\sqrt{7} + \sqrt[3]{7} - \sqrt{7} + \sqrt[3]{7}$

(l) $^{100}\sqrt{10} + ^{100}\sqrt{1}$

A Venn diagram showing different types of numbers

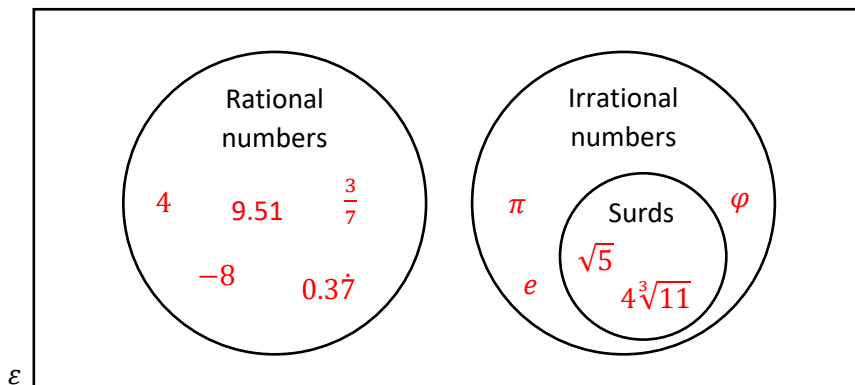
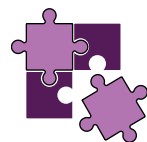

Simplifying Surds

It is possible to use the following rules to simplify surds.



$\sqrt{a} \times \sqrt{a} = a,$
 $\sqrt{ab} = \sqrt{a} \times \sqrt{b}$

Example

$$\sqrt{3} \times \sqrt{3} = 3$$

$$\begin{aligned} \sqrt{8} &= \sqrt{4 \times 2} \\ &= \sqrt{4} \times \sqrt{2} \\ &= 2 \times \sqrt{2} \\ &= 2\sqrt{2} \end{aligned}$$

$$\begin{aligned} \sqrt{15} \times \sqrt{12} &= \sqrt{5 \times 3} \times \sqrt{3 \times 4} \\ &= \sqrt{5} \times \sqrt{3} \times \sqrt{3} \times \sqrt{4} \\ &= \sqrt{5} \times 3 \times 2 \\ &= 6\sqrt{5} \end{aligned}$$

Exercise 28



Complete the following table to show the surds in their simplest form.

(Hint: look for a factor that is a square number.)

$\sqrt{1}$	$\sqrt{2}$	$\sqrt{3}$	$\sqrt{4}$	$\sqrt{5}$	$\sqrt{6}$	$\sqrt{7}$	$\sqrt{8}$ $= 2\sqrt{2}$	$\sqrt{9}$ $= 3$	$\sqrt{10}$
$\sqrt{11}$	$\sqrt{12}$	$\sqrt{13}$	$\sqrt{14}$	$\sqrt{15}$	$\sqrt{16}$	$\sqrt{17}$	$\sqrt{18}$	$\sqrt{19}$	$\sqrt{20}$
$\sqrt{21}$	$\sqrt{22}$	$\sqrt{23}$	$\sqrt{24}$	$\sqrt{25}$	$\sqrt{26}$	$\sqrt{27}$	$\sqrt{28}$	$\sqrt{29}$	$\sqrt{30}$
$\sqrt{31}$	$\sqrt{32}$	$\sqrt{33}$	$\sqrt{34}$	$\sqrt{35}$	$\sqrt{36}$	$\sqrt{37}$	$\sqrt{38}$	$\sqrt{39}$	$\sqrt{40}$
$\sqrt{41}$	$\sqrt{42}$	$\sqrt{43}$	$\sqrt{44}$	$\sqrt{45}$	$\sqrt{46}$	$\sqrt{47}$	$\sqrt{48}$	$\sqrt{49}$	$\sqrt{50}$
$\sqrt{51}$	$\sqrt{52}$	$\sqrt{53}$	$\sqrt{54}$	$\sqrt{55}$	$\sqrt{56}$	$\sqrt{57}$	$\sqrt{58}$	$\sqrt{59}$	$\sqrt{60}$
$\sqrt{61}$	$\sqrt{62}$	$\sqrt{63}$	$\sqrt{64}$	$\sqrt{65}$	$\sqrt{66}$	$\sqrt{67}$	$\sqrt{68}$	$\sqrt{69}$	$\sqrt{70}$
$\sqrt{71}$	$\sqrt{72}$	$\sqrt{73}$	$\sqrt{74}$	$\sqrt{75}$	$\sqrt{76}$	$\sqrt{77}$	$\sqrt{78}$	$\sqrt{79}$	$\sqrt{80}$
$\sqrt{81}$	$\sqrt{82}$	$\sqrt{83}$	$\sqrt{84}$	$\sqrt{85}$	$\sqrt{86}$	$\sqrt{87}$	$\sqrt{88}$	$\sqrt{89}$	$\sqrt{90}$
$\sqrt{91}$	$\sqrt{92}$	$\sqrt{93}$	$\sqrt{94}$	$\sqrt{95}$	$\sqrt{96}$	$\sqrt{97}$	$\sqrt{98}$	$\sqrt{99}$	$\sqrt{100}$

Exercise 29

Simplify the following.

(a) $\sqrt{2} \times 5\sqrt{2}$

(b) $4\sqrt{2} \times \sqrt{8}$

(c) $\sqrt{125}$

(d) $5\sqrt{32}$

(e) $\sqrt{12} + 4\sqrt{3}$

(f) $7\sqrt{5} - \sqrt{45}$

(g) $\sqrt{60} \times 2\sqrt{3}$

(h) $\sqrt{300}$

(i) $\sqrt{32} \times \sqrt{18}$

(j) $5\sqrt{30} \times \sqrt{60}$

(k) $6\sqrt{5} - \sqrt{20}$

(l) $\sqrt{48} + 4\sqrt{3}$

(m) $\sqrt{18} + 8\sqrt{2}$

(n) $\sqrt{8} \times \sqrt{24}$

(o) $5\sqrt{15} \times \sqrt{3}$

**Exercise 30**

Simplify the following.

(a) $\frac{\sqrt{2} \times \sqrt{2} \times \sqrt{5}}{\sqrt{5}}$

(b) $\frac{\sqrt{12} \times \sqrt{3}}{2}$

(c) $\frac{3 \times \sqrt{7} \times \sqrt{2} \times \sqrt{7}}{7\sqrt{2}}$

(d) $\sqrt{7} \times 7^{\frac{1}{2}}$

(e) $(4\sqrt{2})^2$

(f) $(\sqrt{3})^5$

Expanding with surds**Example**

$$\begin{aligned}\sqrt{5}(4 + \sqrt{5}) &= \sqrt{5} \times 4 + \sqrt{5} \times \sqrt{5} \\ &= 4\sqrt{5} + 5\end{aligned}$$



$$\begin{aligned}2\sqrt{3}(5\sqrt{3} - 4) &= 2 \times \sqrt{3} \times 5 \times \sqrt{3} - 2 \times \sqrt{3} \times 4 \\ &= 10 \times 3 - 8 \times \sqrt{3} \\ &= 30 - 8\sqrt{3}\end{aligned}$$

$$\begin{aligned}(\sqrt{3} + 2)(\sqrt{7} - 5) &= \sqrt{3} \times \sqrt{7} - \sqrt{3} \times 5 + 2 \times \sqrt{7} - 2 \times 5 \\ &= \sqrt{21} - 5\sqrt{3} + 2\sqrt{7} - 10\end{aligned}$$

$$\begin{aligned}(4 - 2\sqrt{3})^2 &= (4 - 2\sqrt{3})(4 - 2\sqrt{3}) \\ &= 4 \times 4 - 4 \times 2 \times \sqrt{3} - 2 \times \sqrt{3} \times 4 + 2 \times \sqrt{3} \times 2 \times \sqrt{3} \\ &= 16 - 8\sqrt{3} - 8\sqrt{3} + 4 \times 3 \\ &= 28 - 16\sqrt{3}\end{aligned}$$

Use the acronym
FOIL

Exercise 31

Expand and simplify the following.

(a) $\sqrt{2}(3 + \sqrt{2})$

(b) $4\sqrt{2}(3 + \sqrt{2})$

(c) $4\sqrt{2}(3 + 2\sqrt{2})$

(d) $\sqrt{3}(\sqrt{5} + \sqrt{3})$

(e) $2\sqrt{5}(\sqrt{2} + \sqrt{5})$

(f) $4\sqrt{7}(3 + \sqrt{14})$

(g) $5\sqrt{2}(\sqrt{8} + \sqrt{6})$

(h) $2\sqrt{11}(1 + \sqrt{22})$

(i) $3\sqrt{3}(\sqrt{6} + \sqrt{12})$

Exercise 32

Expand and simplify the following.

(a) $(2 + \sqrt{3})(4 + \sqrt{2})$

(b) $(2 + \sqrt{3})(4 + \sqrt{3})$

(c) $(2 + 3\sqrt{3})(4 + \sqrt{3})$

(d) $(2 + \sqrt{3})(4 - \sqrt{2})$

(e) $(4 - \sqrt{2})(1 + \sqrt{2})$

(f) $(4 - 3\sqrt{5})(1 + \sqrt{5})$

(g) $(\sqrt{7} + 5)(\sqrt{7} - 5)$

(h) $(2 + 3\sqrt{7})(3\sqrt{2} - 5)$

(i) $(10 - 5\sqrt{7})(\sqrt{7} + 4)$

(j) $(3 + \sqrt{5})^2$

(k) $(5 - \sqrt{2})^2$

(l) $(4 + 9\sqrt{5})^2$

Exercise 33

2

(a) Given that $a = \sqrt{2}$, $b = \sqrt{3}$ and $c = \sqrt{12}$, find the value of abc . Write your answer in the form $n\sqrt{2}$ where n is a whole number.

(b) Given that $p = \sqrt{5}$, $q = \sqrt{10}$, $r = \sqrt{50}$, find the value of the following. Note clearly whether your answers are rational or irrational.

(i) pr

(ii) $\frac{pq}{r}$

(iii) $pq + r$

(c) Evaluate $\frac{(3+\sqrt{5})(3-\sqrt{5})}{2}$. Note clearly whether your answer is rational or irrational.

(d) Simplify $\frac{(2\sqrt{5})^2 - \frac{3\sqrt{12}}{\sqrt{3}}}{2}$ and note whether your answer is rational or irrational.

(e) Simplify $(\pi\sqrt{24} - \pi\sqrt{6})^2$, leaving your answer in terms of π .

(f) Write a value for x (with $x > 1$) so that $x^{\frac{3}{2}}$ is rational.

Challenge! 

Patterns are produced as shown in the following diagrams.

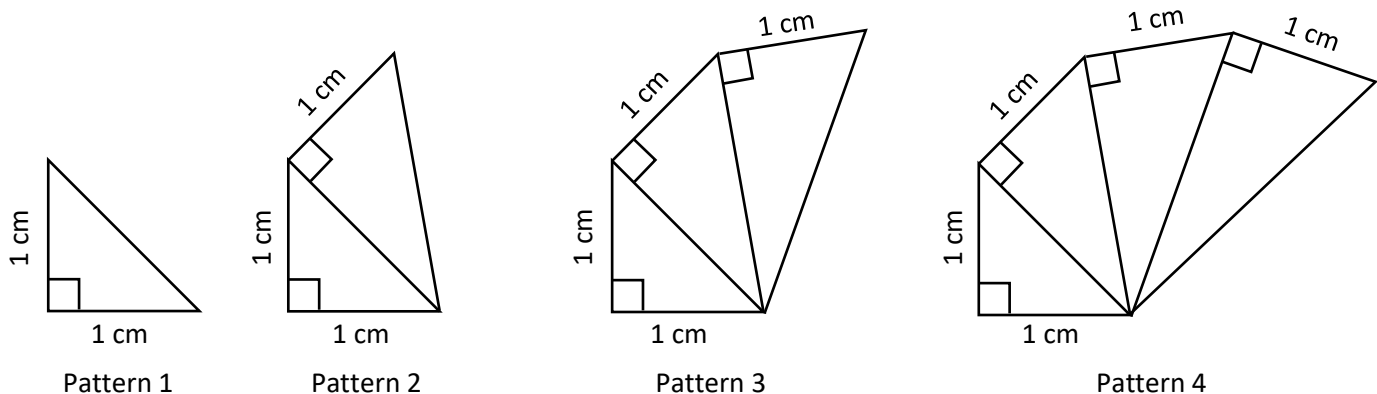

The diagrams are not drawn to scale.

Find the perimeter of Pattern 6 in the form $a + \sqrt{b}$, where a and b are whole numbers. Show all your working.

Evaluation

Key words	Corrections	I am happy with...	I need to revise...

Standard Form

The **standard form** is a special way to write numbers, usually very large or very small numbers.

A number is written in standard form if it has the form

$a \times 10^n,$

where a is a number between 1 and 10 ($1 \leq a < 10$) and n is an integer.

Example

Circle the numbers below that are written in standard form.

3.2×10^5 (circled)

14.2×10^9 (not circled)

7.2×10^{-6} (circled)

0.34×10^{23} (not circled)

-3.2×10^{-5} (not circled)

1×10^7 (circled)

$6.21 \times 10^{0.2}$ (not circled)

$8.7 \div 10^8$ (not circled)

Not a number between 1 and 10.

0.2 is not an integer.

Division, not multiplication.

Exercise 34

Circle the numbers below that are written in standard form.

- | | | | |
|------------------------|-------------------------|-------------------------|-----------------------------|
| (a) 6.7×10^5 | (b) $5.4 \div 10^9$ | (c) 9×10^{-3} | (d) 14.3×10^{12} |
| (e) 0.38×10^6 | (f) 9.3×10^0 | (g) -3.2×10^6 | (h) 10×10^4 |
| (i) 4.5×5^5 | (j) 3×10^{189} | (k) $6 \times 10^{1.4}$ | (l) 5.6721×10^{-9} |

Writing Numbers $x \geq 1$ in Standard Form

Given a number that is greater than or equal to one, this is how we write it in standard form.

a) Add a **decimal point** to the number, if there isn't already one present.

For example, the number 320 would change to be 320.0, and the number 73,000 would change to be 73,000.0.

b) Consider how many times we must **divide the number by 10** in order to reach a number a that is between 1 and 10 ($1 \leq a < 10$). We do this by counting how many times we "jump" the decimal point to the left.

$73,000.0$

(Arrows show jumps from 0 to 1, 1 to 2, 2 to 3, 3 to 4)

c) Use the number between 1 and 10 and the number of times we divided by 10 in order to write the original number in standard form.

$73,000$
 $= 7.3 \times 10^4$

Exercise 35

Write the following numbers in standard form.

- | | | | |
|--------------------|---------------------|-------------------|---------------|
| (a) 54,000 | (b) 234,000 | (c) 8,000 | (d) 3,000,000 |
| (e) 340 | (f) 43,000,000 | (g) 4,328,000,000 | (h) 7 |
| (i) 98,000,000,000 | (j) 823,240,000,000 | (k) 10 | (l) 1 |



Writing Numbers $0 < x < 1$ in Standard Form

Given a number between 0 and 1, this is how we write it in standard form.

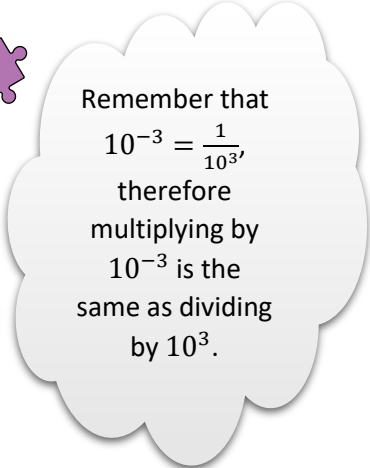

a) Consider how many times we must **multiply the number by 10** in order to reach a number a that is between 1 and 10 ($1 \leq a < 10$). We do this by counting how many times we “jump” the decimal point to the right.

0.00241

b) Use the number between 1 and 10 and the number of times we multiplied by 10 in order to write the original number in standard form.

0.00241
= 2.41×10^{-3}

Exercise 36

Write the following numbers in standard form.

- | | | | |
|-------------------|-----------------|---------------|-----------------|
| (a) 0.00428 | (b) 0.000027 | (c) 0.021 | (d) 0.87 |
| (e) 0.00000689 | (f) 0.4 | (g) 0.0009873 | (h) 0.0901 |
| (i) 0.00000000728 | (j) 0.000000429 | (k) 0.0000502 | (l) 0.999999999 |



Exercise 37

Write the following numbers in standard form.

- | | | | |
|--------------|-------------------|---------------|---------------------|
| (a) 84,200 | (b) 0.000647 | (c) 5,000,000 | (d) 0.005183 |
| (e) 502,050 | (f) 0.0000004 | (g) 0.98 | (h) 852,000,000,000 |
| (i) 0.000201 | (j) 2,384,900,000 | (k) 1.03 | (l) 0.03 |



Changing from Standard Form to an Ordinary Number

Example

(a) Write 6.962×10^6 as an ordinary number.

We must multiply 6.962 by 10 six times.

- | | |
|---------|---------|
| 69.62 | 1 time |
| 696.2 | 2 times |
| 6962 | 3 times |
| 69620 | 4 times |
| 696200 | 5 times |
| 6962000 | 6 times |

The answer is 6,962,000.

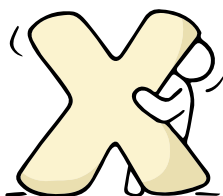

(b) Write 9.62×10^{-5} as an ordinary number.

We must divide 9.62 by 10 five times.

- | | |
|-----------|---------|
| 0.962 | 1 time |
| 0.0962 | 2 times |
| 0.00962 | 3 times |
| 0.000962 | 4 times |
| 0.0000962 | 5 times |

The answer is 0.0000962.

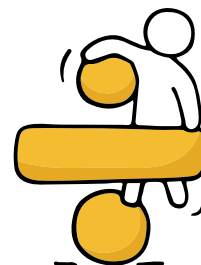

Exercise 38

Write the following numbers, which are in standard form, as ordinary numbers.

- | | | | |
|---------------------------|---------------------------|----------------------------|------------------------------|
| (a) 8.243×10^6 | (b) 4.2×10^4 | (c) 8×10^5 | (d) 3.704×10^8 |
| (e) 6.25×10^{-5} | (f) 1.75×10^{-2} | (g) 8.02×10^{-3} | (h) 6.2829×10^{-7} |
| (i) 7×10^{-2} | (j) 9.2×10^1 | (k) 3.504×10^{-1} | (l) 8.6284×10^{-6} |
| (m) 4×10^0 | (n) 5.289×10^8 | (o) 8.2×10^{-9} | (p) 8.28465×10^{10} |



Almost in Standard Form

In order to multiply and divide numbers given in standard form, we must first learn how to change numbers that are almost in standard form to be in standard form.

**Example**

Change the following numbers, that are almost in standard form, to be in standard form.

$$\begin{array}{l} \text{(a) } 45 \times 10^7 \\ \downarrow \div 10 \quad \downarrow +1 \\ = 4.5 \times 10^8 \end{array}$$

$$\begin{array}{l} \text{(b) } 0.4 \times 10^3 \\ \downarrow \times 10 \quad \downarrow -1 \\ = 4 \times 10^2 \end{array}$$

$$\begin{array}{l} \text{(c) } 68 \times 10^{-4} \\ \downarrow \div 10 \quad \downarrow +1 \\ = 6.8 \times 10^{-3} \end{array}$$

$$\begin{array}{l} \text{(d) } 0.064 \times 10^{-7} \\ \downarrow \times 100 \quad \downarrow -2 \\ = 6.4 \times 10^{-9} \end{array}$$

Divide the number / move decimal point to the left: increase the index.
Multiply the number / move decimal point to the right: decrease the index.

Exercise 39

Change the following numbers, that are almost in standard form, to be in standard form.

(a) 61×10^7

(b) 532×10^7

(c) 0.61×10^7

(d) 0.54×10^7

(e) 61×10^{-7}

(f) 532×10^{-7}

(g) 0.61×10^{-7}

(h) 0.54×10^{-7}

(i) 83×10^9

(j) 0.325×10^{14}

(k) 7324×10^{-5}

(l) 53×10^{-14}

(m) 0.025×10^8

(n) 0.0024×10^{-16}

(o) 10×10^5

(p) 0.63×10^{-43}

Adding and Subtracting Numbers in Standard Form**Method 1: Equal Indices**

Calculate the following, giving your answer in standard form.

$$\begin{aligned} \text{(a) } & (3 \times 10^{15}) + (8 \times 10^{15}) \\ & = 11 \times 10^{15} \\ & = 1.1 \times 10^{16} \end{aligned}$$

The indices are equal so we can add the 8 to the 3.
Change the answer to be in standard form.

$$\begin{aligned} \text{(b) } & (7.2 \times 10^{24}) - (5 \times 10^{23}) \\ & = (7.2 \times 10^{24}) - (0.5 \times 10^{24}) \\ & = 6.7 \times 10^{24} \end{aligned}$$

Change the second number so that its index is also 24.
The indices are equal so we can subtract the 0.5 from the 7.2.

Exercise 40

Calculate the following, giving your answer in standard form.

(a) $(5 \times 10^{12}) + (2 \times 10^{12})$

(b) $(5 \times 10^{27}) + (2 \times 10^{27})$

(c) $(2 \times 10^{27}) + (5 \times 10^{27})$

(d) $(7 \times 10^{27}) + (5 \times 10^{27})$

(e) $(7 \times 10^{27}) - (5 \times 10^{27})$

(f) $(7 \times 10^{-7}) - (5 \times 10^{-7})$

(g) $(6 \times 10^8) + (2 \times 10^8)$

(h) $(6 \times 10^8) + (2 \times 10^7)$

(i) $(6 \times 10^7) + (2 \times 10^8)$

(j) $(6 \times 10^6) + (2 \times 10^8)$

(k) $(6 \times 10^6) - (2 \times 10^5)$

(l) $(6 \times 10^6) - (2 \times 10^4)$

(m) $(9 \times 10^{-5}) - (3 \times 10^{-5})$

(n) $(9 \times 10^{-5}) + (3 \times 10^{-5})$

(o) $(9 \times 10^{-5}) + (3 \times 10^{-6})$

(p) $(9 \times 10^{-6}) + (3 \times 10^{-5})$

(q) $(9 \times 10^{-5}) - (3 \times 10^{-7})$

(r) $(9 \times 10^{-4}) + (3 \times 10^{-6})$

(s) $(7.3 \times 10^8) + (2.6 \times 10^8)$

(t) $(7.4 \times 10^8) + (2.6 \times 10^8)$

(u) $(7.3 \times 10^8) + (2.6 \times 10^7)$

(v) $(7.3 \times 10^{108}) + (2.6 \times 10^{107})$

(w) $(7.3 \times 10^{-108}) + (2.6 \times 10^{-107})$

(x) $(7.3 \times 10^0) + (2.6 \times 10^{-1})$

A



Method 2: Change to ordinary numbers



Calculate the following, giving your answer in standard form.

(a) $(3.4 \times 10^5) + (7.18 \times 10^4)$

(b) $(7.36 \times 10^{-3}) - (1.9 \times 10^{-4})$

	3	4	0	0	0	0
+		7	1	8	0	0
	4	1	1	8	0	0
	1					

	0	0	0	7	² ₃	¹ ₆
-	0	0	0	0	1	9
	0	0	0	7	1	7



Answer: 4.118×10^5

Answer: 7.17×10^{-3}

Exercise 41

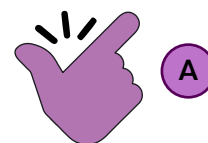

Calculate the following, giving your answers in standard form.

(a) $(2.7 \times 10^3) + (5.26 \times 10^2)$

(b) $(6.152 \times 10^5) + (7.64 \times 10^4)$

(c) $(2.09 \times 10^4) + (4 \times 10^3)$

(d) $(6.29 \times 10^6) + (3.283 \times 10^5)$

(e) $(5 \times 10^4) + (8.024 \times 10^6)$

(f) $(4.2 \times 10^7) + (1.59 \times 10^8)$

(g) $(2.7 \times 10^3) - (5.26 \times 10^2)$

(h) $(6.152 \times 10^5) - (7.64 \times 10^4)$

(i) $(2.09 \times 10^4) - (4 \times 10^3)$

(j) $(8 \times 10^6) - (4.6 \times 10^3)$

(k) $(2.07 \times 10^4) - (9.442 \times 10^3)$

(l) $(1.4 \times 10^2) - (4.6 \times 10^1)$

(m) $(2.7 \times 10^{-3}) + (5.26 \times 10^{-2})$

(n) $(6.152 \times 10^{-5}) + (7.64 \times 10^{-4})$

(o) $(2.09 \times 10^{-4}) + (4 \times 10^{-3})$

(p) $(6.4 \times 10^{-1}) + (7.28 \times 10^{-2})$

(q) $(8 \times 10^{-4}) + (7.4 \times 10^{-3})$

(r) $(1.02 \times 10^{-7}) + (7.32 \times 10^{-6})$

(s) $(5.26 \times 10^{-2}) - (2.7 \times 10^{-3})$

(t) $(7.64 \times 10^{-4}) - (6.152 \times 10^{-5})$

(u) $(4 \times 10^{-3}) - (2.09 \times 10^{-4})$

(v) $(6.43 \times 10^{-4}) - (3.82 \times 10^{-5})$

(w) $(4.6 \times 10^{-7}) - (6 \times 10^{-10})$

(x) $(3.814 \times 10^2) - (4.76 \times 10^{-2})$

Multiplying Numbers in Standard Form

Example

Calculate $(2.5 \times 10^5) \times (6 \times 10^3)$, giving your answer in standard form.

Answer: $(2.5 \times 10^5) \times (6 \times 10^3)$
 $= (2.5 \times 6) \times (10^5 \times 10^3)$
 $= 15 \times 10^{5+3}$
 $= 15 \times 10^8$
 $= 1.5 \times 10^9$

Rearrange (the order in multiplication sums doesn't matter).
 Multiply the numbers; use rules of indices to add the indices.
 This is almost in standard form; we must divide the 15 by 10 to correct...
 Final answer (divide by 10 so add 1 to the index).



Exercise 42



Calculate the following, giving your answer in standard form.

(a) $(2 \times 10^5) \times (4 \times 10^3)$

(b) $(2 \times 10^5) \times (8 \times 10^3)$

(c) $(2 \times 10^5) \times (4 \times 10^{-3})$

(d) $(1.3 \times 10^6) \times (2 \times 10^8)$

(e) $(4 \times 10^9) \times (3 \times 10^4)$

(f) $(7 \times 10^{14}) \times (6 \times 10^2)$

(g) $(4.6 \times 10^7) \times (3 \times 10^4)$

(h) $(7.5 \times 10^{14}) \times (8 \times 10^{23})$

(i) $(7 \times 10^7) \times (3.8 \times 10^9)$

(j) $(6 \times 10^{-4}) \times (6 \times 10^{14})$

(k) $(3 \times 10^6) \times (2 \times 10^{-2})$

(l) $(1 \times 10^{-4}) \times (8 \times 10^{-3})$

(m) $(2.4 \times 10^4) \times (1.5 \times 10^7)$

(n) $(5.3 \times 10^{14}) \times (6.2 \times 10^3)$

(o) $(5.13 \times 10^{-6}) \times (7.4 \times 10^2)$

Dividing Numbers in Standard Form

Example

Calculate $(4 \times 10^8) \div (5 \times 10^2)$, giving your answer in standard form.

$$\begin{aligned} \text{Answer: } & (4 \times 10^8) \div (5 \times 10^2) \\ & = (4 \div 5) \times (10^8 \div 10^2) \\ & = 0.8 \times 10^{8-2} \\ & = 0.8 \times 10^6 \\ & = 8 \times 10^5 \end{aligned}$$

Rearrange

Divide the numbers; use rules of indices to subtract the indices.

This is almost in standard form; we must multiply the 0.8 by 10 to correct...

Final answer (multiply by 10 so subtract 1 from the index).

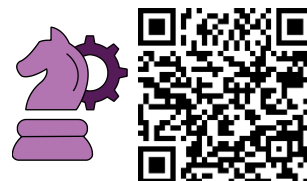

Exercise 43

Calculate the following, giving your answer in standard form.

- | | | |
|---|---|---|
| (a) $(8 \times 10^8) \div (4 \times 10^2)$ | (b) $(4 \times 10^8) \div (8 \times 10^2)$ | (c) $(8 \times 10^8) \div (4 \times 10^{-2})$ |
| (d) $(3.6 \times 10^6) \div (3 \times 10^3)$ | (e) $(6.4 \times 10^{12}) \div (4 \times 10^3)$ | (f) $(9.3 \times 10^5) \div (3 \times 10^5)$ |
| (g) $(8.6 \times 10^7) \div (2 \times 10^2)$ | (h) $(7.5 \times 10^{14}) \div (5 \times 10^{20})$ | (i) $(1 \times 10^8) \div (3 \times 10^4)$ |
| (j) $(4.2 \times 10^{-3}) \div (3 \times 10^4)$ | (k) $(2 \times 10^5) \div (5 \times 10^{-2})$ | (l) $(1 \times 10^{-4}) \div (8 \times 10^{-2})$ |
| (m) $(2.4 \times 10^8) \div (4 \times 10^3)$ | (n) $(5.25 \times 10^{50}) \div (1.5 \times 10^{10})$ | (o) $(2 \times 10^{-5}) \div (8 \times 10^{-15})$ |



Exercise 44

Calculate the following, giving your answer in standard form.

- | | | |
|--|---|---|
| (a) $(6 \times 10^4) + (4 \times 10^3)$ | (b) $(6 \times 10^4) - (4 \times 10^3)$ | (c) $(6 \times 10^4) \times (4 \times 10^3)$ |
| (d) $(6 \times 10^4) \div (4 \times 10^3)$ | (e) $\frac{6 \times 10^4}{4 \times 10^3}$ | (f) $\frac{(6 \times 10^4) + (4 \times 10^3)}{4 \times 10^3}$ |
| (g) $(8.4 \times 10^6) + (2 \times 10^2)$ | (h) $(8.4 \times 10^6) - (2 \times 10^2)$ | (i) $(8.4 \times 10^6) \times (2 \times 10^2)$ |
| (j) $(8.4 \times 10^6) \div (2 \times 10^2)$ | (k) $(8.4 \times 10^6) \times 5$ | (l) $(8.4 \times 10^6) + (2 \times 10^{-2})$ |

Challenge!

Use your calculator to check your answers to Exercise 44, making sure that your calculator shows the answer in standard form.

Exercise 45

The Earth is more or less spherical.

- (a) The radius of the Earth is 6,378.1 km. Calculate the circumference of the Earth, writing your answer in standard form correct to 3 significant figures.
- (b) The surface area of the whole Earth is approximately 5.112×10^8 km². The oceans cover approximately 3.618×10^8 km² of surface area and the rest of the surface area is covered by land. Calculate the amount of surface area of the Earth covered by land, giving your answer in standard form.

Applying

A



Investigation

In the standard form $a \times 10^n$, the number a must be between 1 and 10 ($1 \leq a < 10$) and n is an integer.

Is it therefore possible to write negative numbers using standard form? Use the internet to investigate the answer to this question.

Exercise 46



The Millennium Stadium in Cardiff has enough seats for 74,500 people. The population of Wales would fill the Millennium Stadium 41 times.

Use this information to calculate the approximate population of Wales. Give your answer in standard form correct to 3 significant figures.



Exercise 47

The mass of one hydrogen atom is about

$$1.66 \times 10^{-24} \text{ kg.}$$



One litre of air contains approximately 2.51×10^{22} hydrogen atoms.

(a) What is the mass of hydrogen in one litre of air?

Give your answer in standard form.

(b) Express your answer to (a) without using standard form.

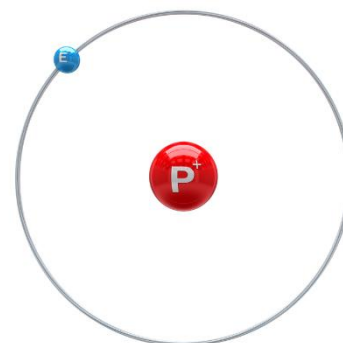

Exercise 48

Currently, Mr. Ben's rice store contains 2,700 kg of basmati rice.

(a) Write 2,700 kg in grams.

Give your answer in standard form.

(b) One grain of rice has mass 0.03 g.

Write the mass of one grain of rice in standard form.

(c) How many grains of rice are in 2,700 kg of rice?

Write your answer in standard form.



Challenge!

Investigate using the internet the meaning of the word googol.

Use your findings to write the number 50 googol in standard form.

Evaluation

Key words	Corrections	I am happy with...	I need to revise...

Plotting Graphs

In year 9, you learnt how to plot linear equations of the form $y = mx + c$. In this chapter, we will learn how to plot equations that have different forms.

Exercise 49

On the graph paper on the right, plot the equation $y = 2x - 3$.

x	0	1	2	3
y				

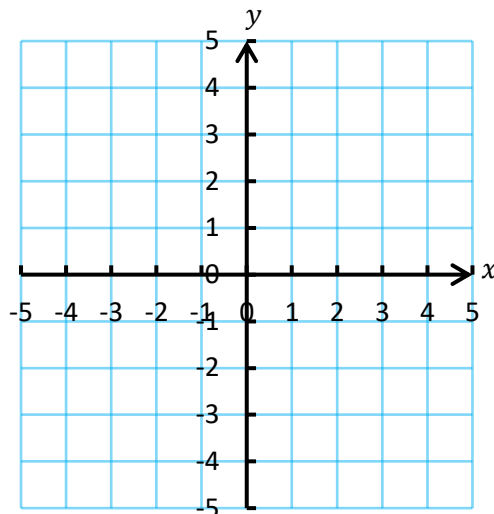

Quadratic Graphs

Equations of the form $y = ax^2 + bx + c$ are **quadratic** equations.

The word quadratic refers to the x^2 term in the equation, a **squared** term. Quadratic graphs have a U or \cap shape.



Exercise 50

Complete the following table to note whether each equation is linear or quadratic.

Equation	Type	Equation	Type
$y = 4x - 2$	Linear	$y = 3x^2 - 4x + 2$	Quadratic
$y = 2x^2 + 4x + 7$		$y = 5x^2 - 4x + 6$	
$y = 2x + 5$		$y = -4x + 2$	
$y = 4x + 7x^2 - 3$		$y = 2 + 6x + 3x^2$	
$y = 3 + 4x$		$y = 6x$	
$y = 5$		$y = 4 + 3x^2$	
$y = -3x^2 + 3$		$y = x(x + 2)$	

Exercise 51

- | | | | |
|------------------|--------------------|------------------------|----------------------------|
| (a) 4×4 | (b) -4×-4 | (c) 4×-4 | (d) -4×4 |
| (e) $4 + 2$ | (f) $4 + -2$ | (g) $-4 + 2$ | (h) $-4 + -2$ |
| (i) $4 - 2$ | (j) $-4 - 2$ | (k) $4 --2$ | (l) $-4 --2$ |
| (m) 7^2 | (n) $(-7)^2$ | (o) $7^2 + 2 \times 7$ | (p) $(-7)^2 + 2 \times -7$ |

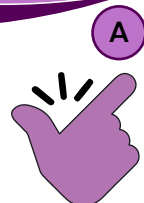

Substitution

To plot a quadratic graph, we can **substitute** values into the associated equation.



2

Exercise 52

Complete the following tables by substitution, before plotting a smooth curve on the graph paper.
(No calculators are allowed.)

x	-5	-4	-3	-2	-1	0	1	2	3	4	5
x^2											
$x^2 - 5$											

(a) $y = x^2$

(b) $y = x^2 - 5$

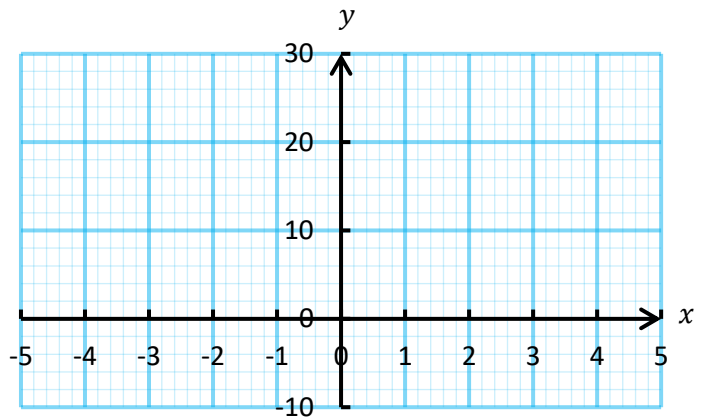
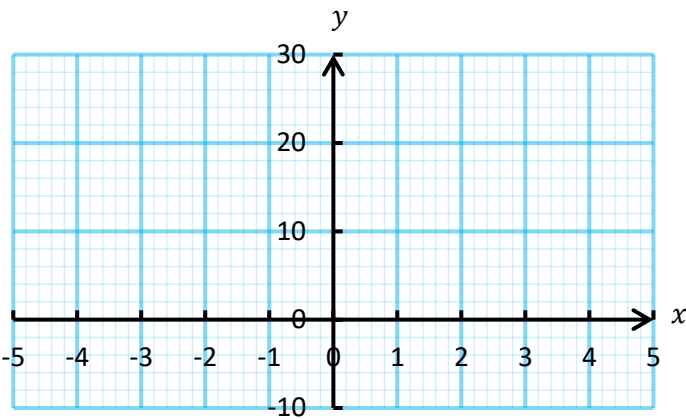

x	-5	-4	-3	-2	-1	0	1	2	3	4	5
x^2											
$2x$											
$x^2 + 2x - 8$											
x^2											
$2x^2$											
$2x^2 - x - 28$											

(c) $y = x^2 + 2x - 8$

(d) $y = 2x^2 - x - 28$

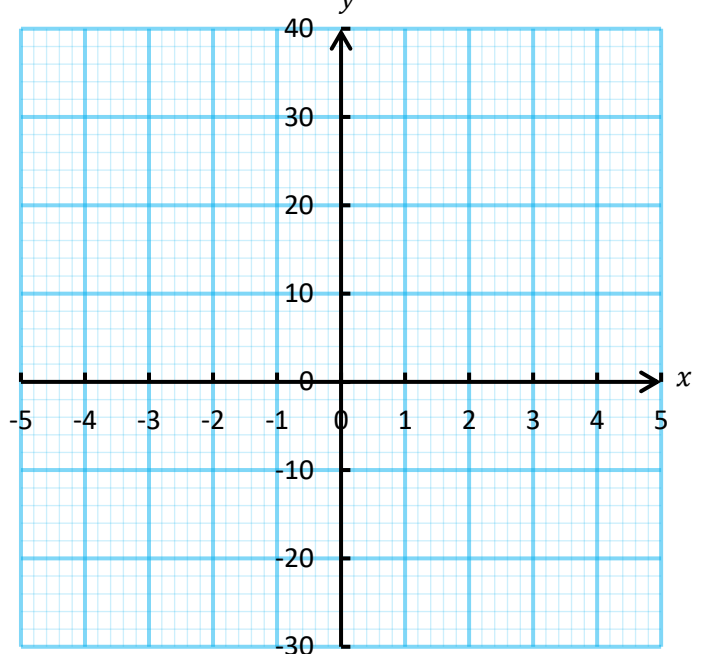
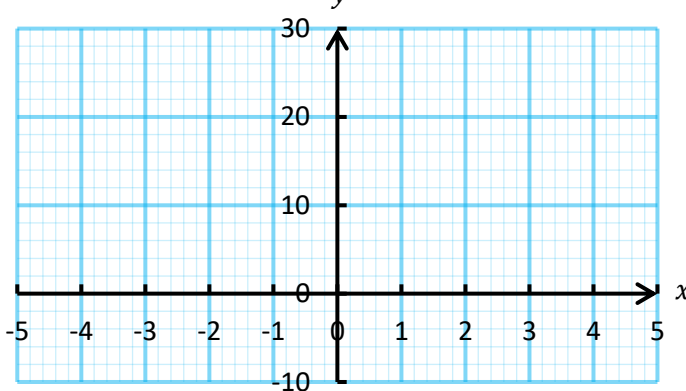

Exercise 53

Fill the blanks in the tables below. Then, in your books, plot suitable graphs for the equations.

(a)	x	-5	-4	-3	-2	-1	0	1	2	3	4	5
	$y = x^2 + 4$	29	20		8	5	4	5	8	13		29
(b)	x	-5	-4	-3	-2	-1	0	1	2	3	4	5
	$y = 3x^2 - 10$	65	38	17		-7	-10	-7		17	38	65
(c)	x	-5	-4	-3	-2	-1	0	1	2	3	4	5
	$y = 4x^2 + x - 7$	88		26	7	-4	-7	-2	11		61	98

Exercise 54

2

Plot appropriate graphs for the following equations.

- (a) $y = x^2 - 4x$
- (b) $y = x^2 - 3x + 4$
- (c) $y = 3x - x^2$
- (d) $y = x^2 - x - 5$
- (e) $y = 5 - 2x^2$
- (f) $y = 3x^2 + 4x + 2$
- (g) $y = 15 - x^2 + 3x$
- (h) $y = 4x^2 - x + 7$
- (i) $y = -2x^2 + 5x - 6$

Recognising and sketching graphs of the form $y = ax^2 + b$



Exercise 55

You will need to use the website www.desmos.com/calculator to complete this exercise.

Type $y = ax^2 + b$ into the box. When the “add slider” option appears click “all”.

What effect does changing the values of a and b have on the graph?

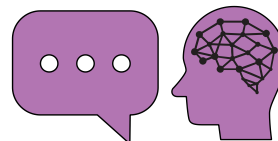

Exercise 56

Pair the graphs and the equations.

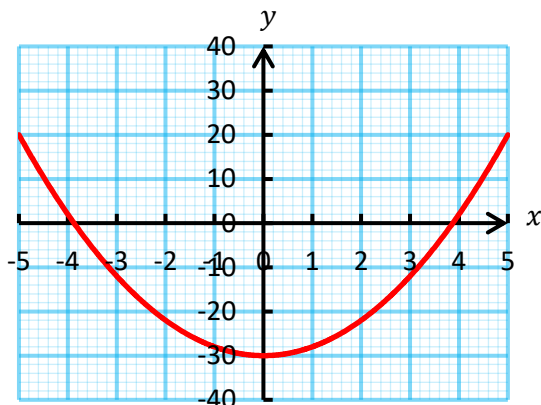

$y = -5x^2 + 30$

$y = 5x^2 - 30$

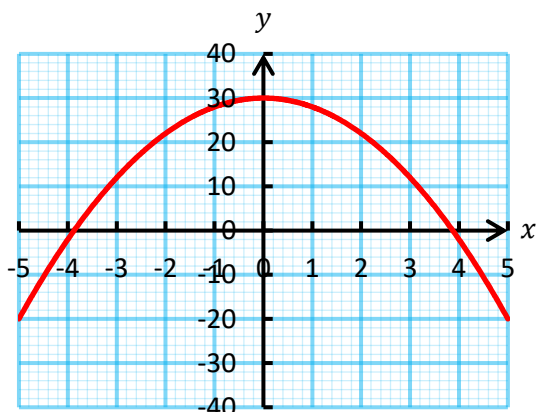
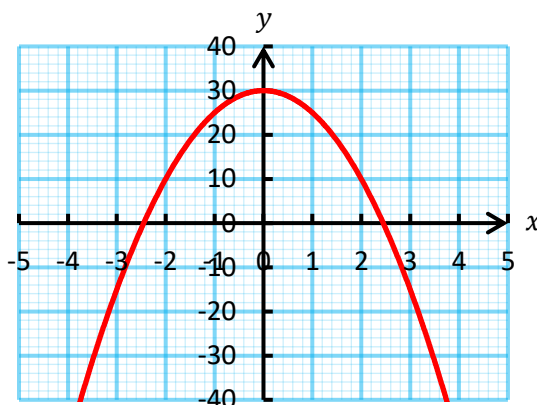

$y = -2x^2 + 30$

$y = 2x^2 - 30$

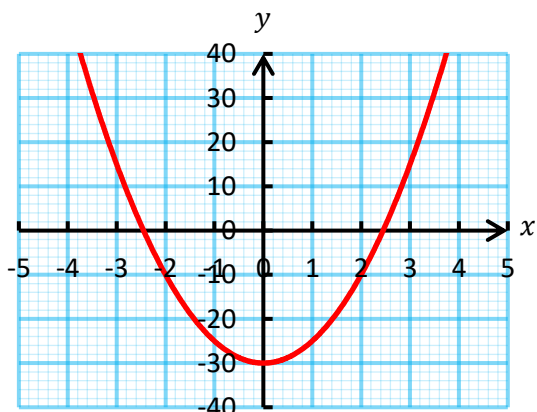

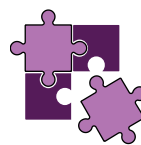

Graphical method of solving equations of the form $x^2 + ax + b = 0$

Consider the graph shown on the right for the equation $y = x^2 + 2x - 8$. To solve the equation $x^2 + 2x - 8 = 0$, we can use the graph to see where the graph crosses the x -axis (this is where the function $x^2 + 2x - 8$ is zero). We see that the graph crosses the x -axis at the points where $x = -4$ and $x = 2$, therefore the solutions to the equation $x^2 + 2x - 8 = 0$ are $x = -4$ and $x = 2$.

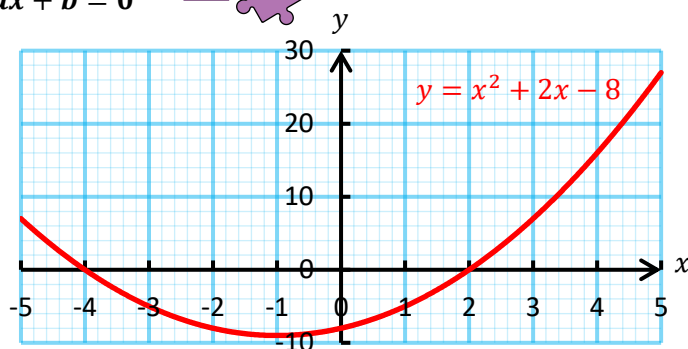

Exercise 57

2

(a) Use the graph below to solve the equation $x^2 - x - 6 = 0$.

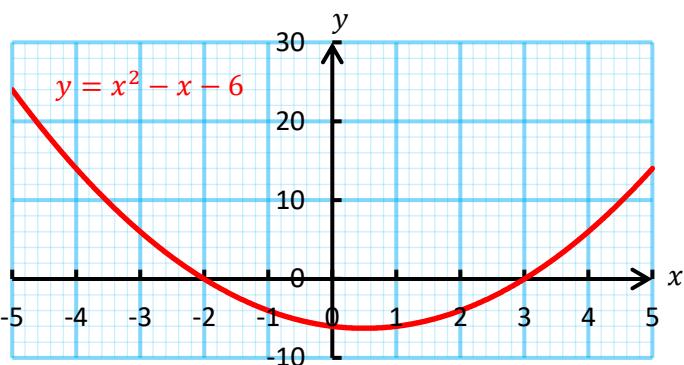

(c) Use the graph above to solve the equation $x^2 - x - 6 = 10$.

Give your answers correct to one decimal place.

(d) Use the graph below to solve the equation $-x^2 - x + 6 = 0$.

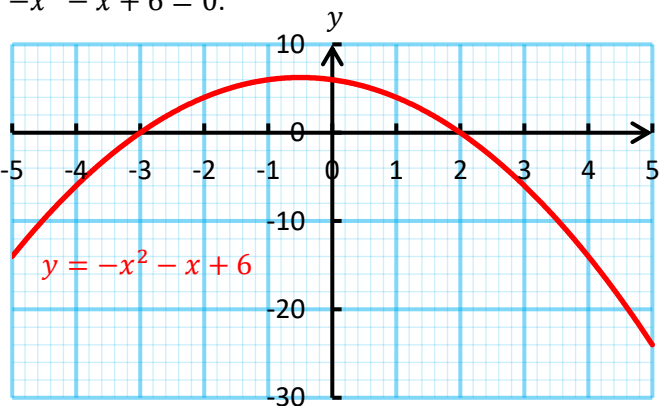

(f) Use the graph above to solve the equation $-x^2 - x + 6 = -10$.

Give your answers correct to one decimal place.

(h) (i) By drawing a suitable graph, solve the equation $x^2 + 3x - 4 = 0$.

(ii) Use your graph from part (i) to solve the equation $x^2 + 3x - 4 = 5$.

Give your answers correct to one decimal place.

(b) Use the graph below to solve the equation $-x^2 + 5x - 4 = 0$.

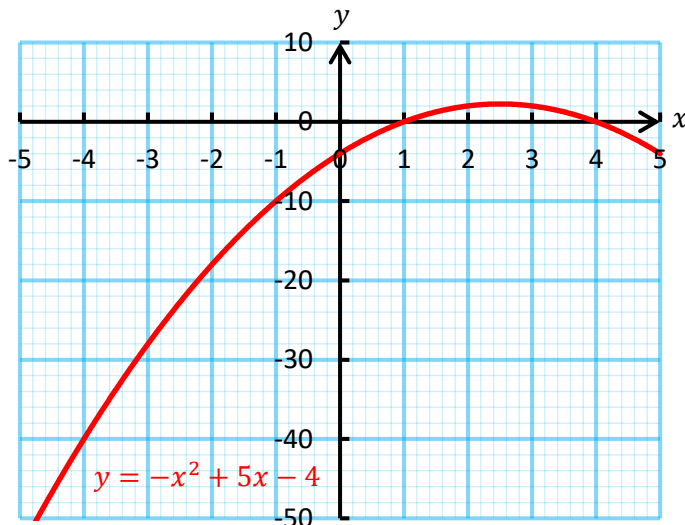

(e) Use the graph below to solve the equation $x^2 - 3x = 0$.

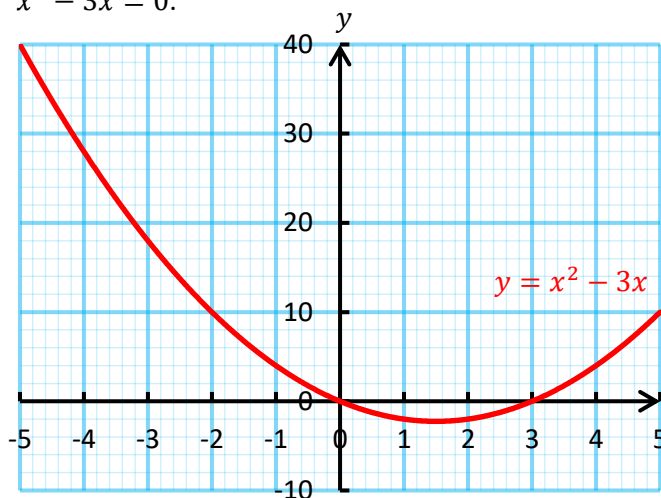

(g) Use the graph above to solve the equation $x^2 - 3x = 4$.





Other Graphs

For the higher tier, you must be able to...

- recognise and sketch **quadratic** graphs of the form $y = (ax + b)(cx + d)$,
- recognise and sketch **reciprocal** graphs of the form $y = \frac{a}{x}$;
- recognise and sketch **cubic** graphs of the form $y = ax^3$;
- draw and interpret **cubic** graphs of the form $y = ax^3 + bx^2 + cx + d$;
- solve $ax^2 + bx + c = dx + e$ or $ax^3 + bx^2 + cx + d = ex + f$.



Exercise 58

Fill in the blanks in the following tables. Then, on the graph paper at the bottom of the page, plot appropriate graphs for the equations.

(a)

x	-5	-4	-3	-2	-1	0	1	2	3	4	5
$y = \frac{1}{x}$											

(b)

x	-5	-4	-3	-2	-1	0	1	2	3	4	5
$y = x^3$											

(c)

x	-5	-4	-3	-2	-1	0	1	2	3	4	5
$y = (2x + 3)(x - 2)$											

(a)

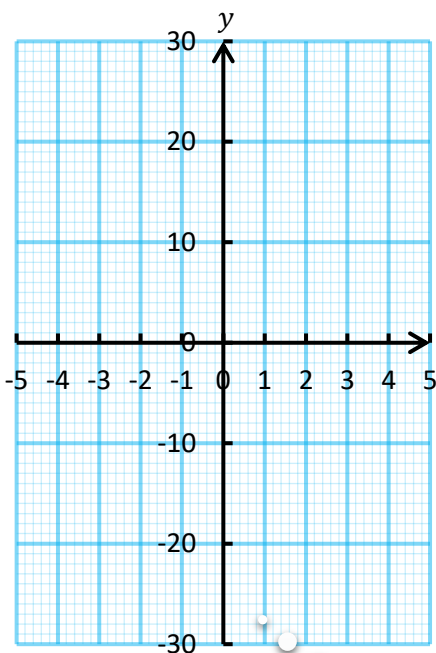

(b)

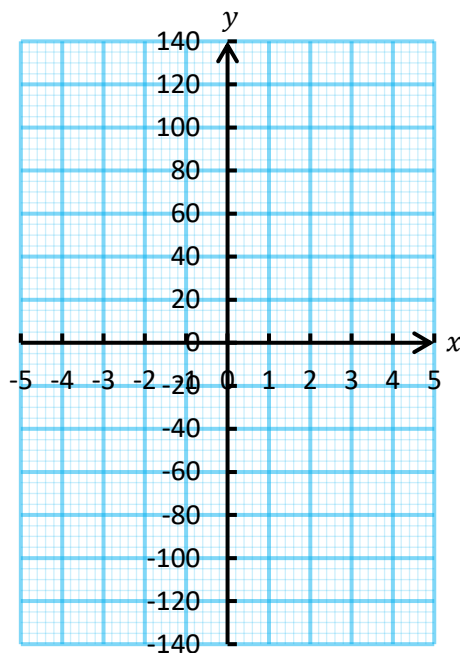

(c)

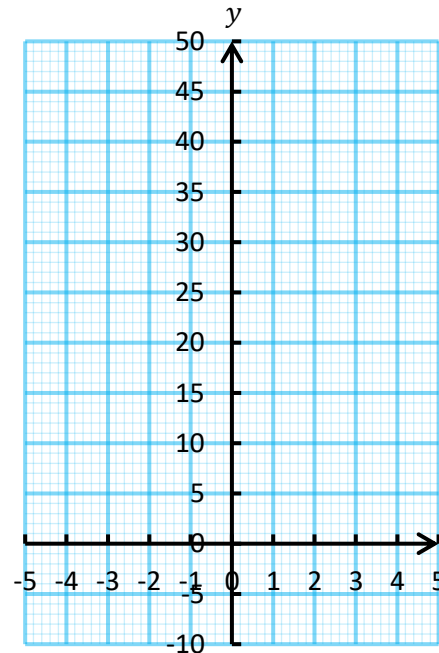

Plot additional points between -1 and 1 for a more accurate graph.



Exercise 59

Plot suitable graphs for the following equations.

(i) $y = x^3 - 4x$

(ii) $y = x^3 + 5x^2 - 2x + 5$

(iii) $y = -x^3$

(b) Use your graphs from part (a) to solve the following equations. Where necessary, write your answers correct to one decimal place.

(i) $x^3 - 4x = 0$

(ii) $x^3 + 5x^2 - 2x + 5 = 20$

(iii) $-x^3 = 0$



Exercise 60

Use the Desmos website (www.desmos.com/calculator) to investigate the graphs for the equations on the top of the previous page. Write a paragraph summarising your findings. Remember to discuss the general shape of each graph, and describe what happens as you change the parameters.

Example

In order to solve $2x^2 - x - 8 = 2x + 1$,

(a) Plot $y = 2x^2 - x - 8$ and $y = 2x + 1$ on the same graph, as shown on the right.

(b) Consider where the graphs intersect. The intersections occur when $x = -1.5$ and $x = 3$, so these are the solutions to the original equation.

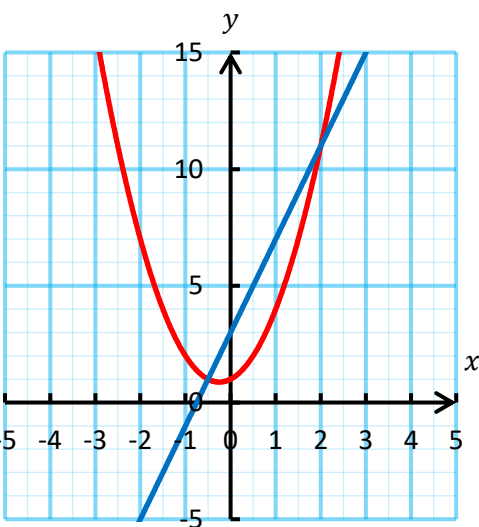
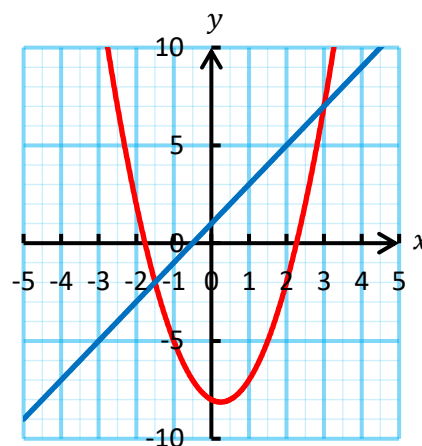

Exercise 61

The graphs for $y = 2x^2 + x + 1$ and $y = 4x + 3$ are shown on the left. Use the graphs to solve the equation $2x^2 + x + 1 = 4x + 3$.

Exercise 62

Use your graph from Exercise 59 to solve the equation $x^3 + 5x^2 - 2x + 5 = x + 10$. Give your solutions correct to one decimal place.



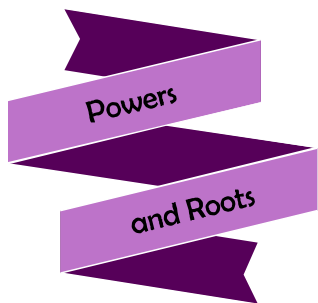

Key words	Corrections	I am happy with...	I need to revise...



Reflection Sheet

Name:

Percentage in the test:

	I know this. 	I need to revise this. 	Question in the test	Correct in the test?
I know how to change between ordinary numbers and numbers written in index form .			1	
I know how to use the multiplication rule $n^a \times n^b = n^{a+b}$.			2	
I know how to use the division rule $n^a \div n^b = n^{a-b}$.			2	
I know how to use the zeroth index rule $n^0 = 1$.			2	
I know how to use the rule where a power is raised to another index , $(n^a)^b = n^{a \times b}$.			2	
I know how to use the negative index rule $n^{-a} = \frac{1}{n^a}$.			2	
I know how to use the unitary fraction index rule $n^{\frac{1}{a}} = \sqrt[a]{n}$.			2	
I can simplify algebraic expressions using the rules of indices.			3	
I know how to use the general fraction index rule $(\sqrt[b]{n})^a = n^{\frac{a}{b}} = \sqrt[b]{n^a}$.			2	
I can combine the rules of indices.			2	
I can differentiate between rational numbers and irrational numbers .			6, 9	
I can collect like surd terms , e.g. $3\sqrt{2} + 7\sqrt{2}$.			7	
I can simplify surds , e.g. $\sqrt{32}$, $\frac{\sqrt{8} \times \sqrt{2}}{2}$.			7, 9	
I can expand using surds , e.g. $4\sqrt{7}(\sqrt{7} + 3)$, $(4 + \sqrt{5})(\sqrt{5} - 2)$.			8	
I can write numbers in standard form .			4	
I can add and subtract numbers written in standard form.			5	
I can multiply and divide numbers written in standard form.			5	
I can solve problems using standard form.				
I can plot quadratic graphs .			10	
I know how to recognise and sketch quadratic graphs .			11	
I know how to use a graphical method to solve quadratic equations.			10	
I know how to recognise and sketch other graphs, e.g. reciprocal graphs ; cubic graphs .			11	